

Dystonia writer's cramp and botox in WCs – Study with ARTEMG 2

Venkateshwarla Rama Raju

Senior Professor, Principal Investigator, Dept. of CSE & Neurology, CMR College of Engineering & Technology, Hyderabad, India,
Nizam's Institute of Medical Sciences, Hyderabad, India

*Corresponding Author: Venkateshwarla Rama Raju

Email: drvenkateshwararr@gmail.com

Abstract

Botulinum toxin (BoNT) in writer's cramp: The use of BoNT to treat limb dystonia requires thoughtful technique including customization of doses and muscle selection. Twelve patients with writer's cramp (8 with concordant and 4 with discordant MMs) were assessed. On comparison of the measures of dispersion; D group had statistically significant difference between LHWS and RHWS (variance, standard deviation and F ratio) with a larger variance in RHWS, as compared to C group where variances and SD were equal or smaller in the RHWS compared to LHWS. Mean amplitudes for RHWS and LHWS for the same muscles, though differ significantly in statistical terms, showed a consistent pattern only in the fifth muscle with a larger mean amplitude on left side in all patients and were not of value in differentiating between concordant (C) and discordant (D) groups of patients.

Keywords: Botulinum Toxin, Botox, Mirror dystonia, dystonia, writer's cramp, Electromyography EMG, Left hand writing signals, right hand writing signals.

Introduction

American Academy of Neurology (AAN) recently reviewed the various trials proving the efficacy of BoNT for focal limb dystonia.¹

A large trial conducted by Kruisdijk JJ et.al.² randomized 40 patients (class I) with writer's cramp in a double-blind design to BoNT or an equivalent volume of saline placebo. Injected muscles were chosen based on clinical examination. Participants with inadequate or no response were offered a second injection 1 month later. The primary outcome measure was the subject's stated desire to continue injection. Seventy percent of those randomized to BoNT wished to

continue treatment compared to 32% of those receiving placebo ($p=0.03$). Significant improvement was also found in BoNT-injected subjects compared to those receiving placebo in secondary outcome measures including a visual analog scale, symptoms severity scale, writer's cramp rating scale, and assessment of writing speed, but not in the functional status scale. Temporary weakness and pain at the injection site were the only adverse events reported.²

Similar results of various smaller placebo controlled trials evaluating the efficacy of BoNT in writer's cramp (Class II trial) are given below in the table.¹⁻³

Table 1: Trials demonstrating efficacy of botulinum toxin

Class	Design	Cohort Size	Treatment - Serotype/brand/dose	Follow-up	Outcome measures/Results (1-primary, 2-secondary)	Drop outs	Adverse Events	Results/ Effect Size
II ²	Double-blinded, randomized, prospective, placebo-controlled cross-over	17 limb dystonia: (10 occupational 1 cramp, 3 idiopathic, 2 post-stroke, & 2 PD)	Serotype/brand not specified 3 active doses: individualized, half, normal or double	1 mo	1.Blinded scoring of videos and handwriting analysis 2.Subjective patient rating	1	Focal weakness with 53% injections, more common with higher dose, lasted 6 wks; muscle stiffness, pain, malaise, muscle twitching, paresthesia, nausea	No significant change in blinded rating: 59% improved with BoNT vs. 38% with placebo Subjective patient rating improved in 82% with BoNT, vs. 6% with placebo
II ³	Blinded, randomized, prospective, placebo-controlled cross-over	20/ writer's cramp	A/Botox® individualized	0.5 & 1.4 mo	1.Writing speed, accuracy, and writing samples and 2.patients' subjective report	none	100% had weakness in injected muscles; pen control worse in 1 pt injected with BoNT	Speed and accuracy improved in 35% with BoNT; Gibson maze improved; pain improved in 67% with pain No improvement with placebo. NNT for significant improvement in writing = 5
II ⁴	Blinded, randomized, prospective, placebo controlled cross-over	10/ focal hand dystonia	A/Botox®: Individualized	0.5 mo	1.Patient subjective rating 2.Objective writing accuracy and speed 2.Physician rating	none	Focal weakness in 80% of BoNT-treated muscles	Subjective: 90% had at least mod improvement. Objective: 6 better with BoNT. 1 pt improved with placebo.

As per the guidelines issued by American Association of Neurology (AAN), botulinum toxin remains the currently available best treatment for Writer's cramp (Level B recommendation).⁵ (Based on the above trials AAN has issued a Level B recommendation for the use of botulinum toxin in patients with writer's cramp.)⁷⁹

Selection of muscles for botulinum toxin injection

Selection of appropriate muscles for injecting botulinum toxin is one of the main factors determining the effectiveness of therapy as the ideal therapy would be to inject in only the dystonic muscles sparing the non affected muscles.

Methods of selection

Clinical and videographic examination: The patient is examined at rest and during writing a long paragraph, drawing a straight line or spirals. The test is done with the patient seated comfortably and writing on a table and the appearance of dystonia is noted. However, the complexity of such movements often makes it difficult to determine which movements are dystonic and which are part of the⁴ normal pattern for that activity. The analysis of dystonic patterns may be further complicated by the presence of compensatory movements that may not be voluntary or even conscious. To improve the selection of muscles, it has been suggested that patients should be examined for abnormal postures at rest and while carrying out the affected task in question as well as other tasks (such as using a cup or a comb).⁴ Simple techniques such as the localization of subjective pain and fatigue accompanied by palpation of the area of discomfort have also been used.⁴ This can probably explain the difference in treatment efficacy with botulinum injection in wrist flexor and extensor dystonia. Previous studies have shown that treatment is more effective in wrist extensor compared to wrist flexor dystonia.^{5,6}

Mirror dystonia

Mirror dystonia in writer's cramp has been described since a long time. There is emergence of dystonic movement in the affected limb even when it is relaxed and the opposite limb is activated. The pathogenesis of this mirror dystonia is still not very clear but may be secondary to abnormal cortical inhibition and decreased selectivity of muscle patterns for highly skilled manual tasks. The importance of recognition of mirror dystonia in patients with writing dysfunction was initially highlighted by Jedynek et al.⁴ He reported that 29 (44%) of 65 patients with writer's cramp had evidence of mirror dystonia and suggested that mirror dystonia may be useful in muscle selection. Subsequently studies have shown a higher incidence of mirror dystonia (70% by Borgohain et al, 2002)⁶ among patients with writer's cramp. The concordance of mirror dystonia with the dystonic movements in writer's cramp has been studied and it has been shown that the best response occurs if there is concordance between the two parameters. In case of discordance as has been noted in wrist flexor dystonia, injection of muscles noted in mirror dystonia has been shown to lead to a better outcome. Mirror

dystonia probably helps in differentiating the primary from the compensatory movements.^{6,7}

EMG in writer's cramp

Electromyography (EMG) is routinely used for guiding botulinum injections into muscles once muscle selection is over.^{4,5} Use of routine EMG in selecting muscles for injecting botulinum toxin may be of assistance, but is limited by the fact that restricted random EMG sampling may give limited unrepresentative information. Further EMG findings may be confounded by compensatory movements and local discomfort caused by EMG wires. To overcome these issues, microelectrodes inserted into multiple muscles can record the EMG during the activation of the dystonia and can provide substantial information on the involvement of deep or not obvious muscles.

EMG – EMG coherence

Recently studies are conducted using sophisticated analyses of EMG discharges in dystonia. These have the potential to disclose the character of the descending discharges responsible for the abnormal muscle activity. For example, frequency analysis can differentiate idiopathic

Dystonic torticollis from voluntary torticollis, as patients with dystonic torticollis exhibit an abnormal synchronized drive to agonistic sternocleidomastoid and splenius capitis muscles with a frequency of 4 to 7 Hz.⁸ This may be secondary to oscillatory activity in pallidial neurons being transmitted to corticospinal tract.

Similarly in writer's cramp, Toro and colleagues found that the EEG power decrease at around 20 Hz upon movement (movement related electroencephalographic desynchronization) is impaired in patients with writer's cramp, possibly due to deficient inhibition by sub cortical structures such as the basal ganglia. This suggested that the oscillatory cortical drive to muscle might be less reactive and generally increased in writer's cramp.⁹ On studies of frequency analysis this is shown as a discrete peak in EMG–EMG coherence at 11 to 12 Hz in patients with writer's cramp.

There are very few studies on multi site microelectrode with multi-channel EMG recording and analysis of EMG–EMG coherence in multiple patients with writer's cramp and detailed assessment using these newer innovative techniques may be helpful in detecting and improving the efficacy of treatment with botulinum toxin by better selection of involved muscles.

The advent of high speed computers has made it possible to effectively apply a host of methods to quantify electromyographic (EMG) signals and their changes in neurogenic (or neuropathic), myogenic (or myopathic) and other abnormalities, such as dystonia. The work in the present study provide design–fabrication and development of multi-channel EMG hardware and also quantitative techniques used to analyze alterations in the EMG signal (waveforms) patterns of writer's cramp patients during writing and during mirror movements (i.e., movements in the right hand (RH) when writing with the left hand (LH).

Hypothesis / Rationale

The main HYPOTHESIS is that when a Writer's cramp (WC) patient writes with an abnormal posture, it is difficult to determine if that posture is because of the primary dystonic force or if a compensatory force (exerted by the WC patient) has overcome the primary dystonic force and has resulted in that posture.

One way to differentiate those two would be to look at the mirror movements. Mirror movements (MMs) are seen in the right hand while writing with the left hand.

In case the primary dystonic force is resulting in the abnormal posture while writing with the right hand, the MMs would be in the same direction i.e., they would be concordant. If a compensatory force (overcoming the primary dystonia) has resulted in the posture, this would be seen in the MMs which would be in the opposite direction i.e., they would be discordant.

We hypothesize that there is no EMG recognizable difference in MMs of concordant and discordant patients. If the data reveal that there are significant differences in MMs of the two groups of patients (as we expect it to be) our expectation that there is EMG recognizable difference between the groups is justified and the analysis can lead to clinically meaningful insight.

Aims and Objectives

The primary aim of this thesis is to determine if there is a quantifiable EMG difference in Writer's Cramp (WC) patients with concordant mirror movements (MMs) from those with Discordant MMs.

The secondary aim was to design and fabricate a multi-channel EMG system to record from 5 muscles simultaneously using innocuous fine nylon coated micro-wires (each of 50 micron (μ) diameters) and required software to analyze quantitatively.

Endpoints

Primary

Difference in EMG signals from the right hand (RH) in writing with either hand between patients with Concordant and Discordant MMs in

1. Amplitude means.
2. Amplitude means differences, and their t-values and p-values.
3. Variances, f-ratios and p-values.
4. Standard deviations.

Secondary

1. Patterns of significance of values for difference in means.
2. Patterns of significance of f-values for the ratios of variances.
3. Analysis of variances for means and standard deviations (SDs).

4. Singular value decomposition of means and standard deviations (SDs)
5. Canonical correlation analysis
6. Correlation data analysis computations for individual patients
7. Similarity investigations of means (t-values) variances (f-ratios)
8. Noise suppressed signal studies
9. Principal component analysis and cluster analysis based on means and variances,
10. EMG – EMG coherence

Tertiary constructing a specially designed EMG with 5 channels

A new multi-channel EMG system with micro wire fine innocuous electrode recoding in the digitized form having a high sampling frequency going up to 6 kHz, maximum conversion of A/D converter of 40 k samples/s was indigenously developed by us at NIMS neurology department. Because of the limited computer system bus capacity (12 MB) of the interface, the sampling frequency of 6 kHz was provided for each channel of 5 channel EMG machine.

All 5 channels sampled simultaneously at 3 kHz. The continuous analogue signals while displayed on the 15 MHz frequency Oscilloscope (Philips dual tracer) are parallelly on-line recorded digitally stored (using a 12 bit A/DC card embedded in computer, Dynalogue company, Denmark) into 32 bit Pentium processor intel-chip computer (having complex reduced instruction set with pipeline techniques fetched and pre-fetched while one operation instruction being performed the other instruction is carried out) sampled at the discrete level.

Multi-channel i.e. multiunit or multi-site signal acquisition (massive curved data streams) helps in microelectrode recording (at multiple muscle sites from several muscles) concurrently and is useful in studying movement (dystonic writer's cramp) and gait disorders, and this concurrency is achieved through systems maximum throughput which is multiplexed (the product of channels) and the maximum sampling rate of each channel. [Note: Maximum throughput is one of the most limiting factors in data (signal, image, etc.) acquisition and hence, one of the most important criteria then selecting an A/DC card.]

Patients and Methods

Patients

12 consecutive patients (M: F =11:1) diagnosed to have writer's cramp were included in the study done from March 2000 to 2003. All patients were right handed individuals

All patients were informed about the study and written informed consent was obtained from them. Detailed clinical history using a standardized questionnaire was taken from all. The clinical details of the 12 patients are given in table 5.

Table 2: Patient characteristics and clinical details

Writer's cramp *							
Case No	Age (Year)	Sex	Occupation	Handedness	Duration (yrs.)	Date of Recording	5 th Muscle
A1	41	Male	Teacher	Right	12	16/02/02	APL
A2	61	Male	Veterinary Doctor	Right	5	08/02/02	EDC
A3	43	Male	Bus Conductor	Right	3	15/06/02	EPL
A4	30	Male	Bank employee	Right	6	29/01/00	FPL
A5	15	Male	10th class Student	Right	2	03/01/02	EPL
A6	42	Male	Excise controller	Right	1.6	11/05/02	FPL
A7	55	Male	Quality controller	Right	40	03/09/02	EIP
A8	39	Male	Doctor	Right	5	10/08/02	EIP
A9	16	Male	10th class student	Right	5	15/06/02	FPL
A10	41	Male	Bank manager	Right	2.5	19/06/02	EPL
A11	39	Female	Solicitor	Right	10	03/05/02	APB
A12	41	Male	Clerk	Right	12	18/06/02	EPL

Videorecording during assessment of dystonia and mirror movements were done after consent for later perusal. All patients were initially asked to write with their right (dominant) hand for 4 minutes and then with left (non-dominant) hand for another 3 to 4 minutes using a standardized protocol. During the latter phase, they were asked to maintain the right-hand flexed on the elbow in a semi-pronated position and the wrist in a neutral position, with fingers being kept relaxed in a semi-flexed position. The right hand was observed for mirror movements (MMs) while writing with their left hand. Writer's cramp severity was graded according to the writer's cramp rating scale by a neurophysician.⁹

Videotaping was done serially from two angles during the procedure.

EMG recording

Sterile nylon coated innocuous fine wire electrodes were introduced into five muscles for a detailed and muscle specific EMG recording.

As most discordant muscle movements are those of wrist, 4 muscles causing flexion and extension of wrist viz, ECR, ECU, FCR, FCU were analyzed in all patients and one more muscle (as decided by the Neurologist, for example, ADP, APL, etc. which showed the maximum discordance of mirror dystonia) on the right hand was included. The fifth muscle selected for each patient is given in table 1

EMG signals were simultaneously recorded from all five muscles while the patients wrote with their right hand (Right hand writing signal – RHWS) and then with their left hand (left hand writing signal – LHWS)

Microelectrodes

A set of five miniature microelectrodes each 50 micron, from California Fine Wire Company, USA, were used in each patient.

Since the electrodes are inserted into specific target muscles, unlike in the case of surface EMG, flexor electrode amplifiers contributed only to flexor contraction muscles

(i.e., FCR, FCU, during writing during mirror movements), extensor electrode amplifiers contributed only to extensor contraction muscles (i.e., ECR, FCR, during writing and during mirror movements) and 5th electrode amplifier contributed only to 5th muscle contraction (i.e., ADP/APB, etc) during writing and during mirror movements.

Motor control system

The motor control system is a complex neural system with a myriad of pathways. One of its output pathways consists of the ensemble of α -motoneurons which activates the skeletal muscle-fibres. One way to study this output pathway in humans is to record the 'motor unit potentials' ('if a sufficiently strong stimulus, e.g., if an electric shock is applied to whatsoever to the part of a nerve or muscle fiber, it will give rise to an excitation, the main manifestation of which there is a great rapid varied variation of the membrane potential (due to change in the ion permeability of the membranes), which is known as the action-potential' can be registered by two methods: by means of electrodes applied to the outer surface of an extra-cellular fiber, and by means of a microelectrode introduced into the protoplasm—intracellular associated with firings of individual motor units (MU's) or motor neurons by means of indwelling ('needle' or 'wire') electrodes placed in a target and/or specific muscle.

EMG system

A suitable multi-channel EMG system was designed and fabricated having to record EMG signals simultaneously with a set of five, micro-miniatured intra muscular cellular nylon coated fine micro wire-electrodes (each 50 micron diameter). The 'prototype' developed for the present study is described below:

It consists of

1. Hardware parts
2. Software

Hardware

1. A 12-bit analogue to digital converter (PCL-8185, Dynalog makers, Denmark) controlled by the real time software program developed here interfaced with Pentium-III computer.
2. A multi-channel EMG instrumentation set encompassing 5 channel signal averagers/ amplifiers both instrumentation and differential amplifiers
3. A set of five innocuous active micro-miniature intramuscular, i.e., extra-cellular nylon coated fine micro-wire electrodes (each 50 micron diameter), and a set of five crocodile-clips for micro-wire electrodes along with a common ground (Ag-silver) electrode and a common reference (Ag-Silver) electrode.
4. A common reference electrode (Ag-Ag/Cl - Silver), for all amplifiers, and an individual reference electrode, for every individual amplifier.
5. A common ground electrode, for all amplifiers and an individual ground electrode for every single amplifier.
6. A master gain control common for all amplifiers
7. A 15MHz Cathode Ray Oscilloscope (Philips) to view the waveforms/ signals, multiplexers
8. An analogue signal/function generator, frequency range from 1 to 15 MHz (Philips company dual tracer)
9. A PCLD-8115 hardware wiring Terminal Board (64-PIN connector as an extension interconnected to the EMG instrument and to the Pentium-III computer. The analogue signals being displayed on the CRO are brought out via this connector and simultaneously sent to the ADC with which the signals are digitized and parallelly stored into the Pentium-III computer.
10. Auxiliary storage devices: floppies, discs, Recordable/Re-writable Compact Disc-Read Writer, read only compact discs, and a Digital Versatile Devices.
11. cartridge data tapes/ Tar devices, A Microtek's multimedia sound card with a multimedia computer speaker system
12. A 32 bit micro processor (with dual core 32 bit internal and external registers, address bus, data and control bus) with fetch and pre-fetch pipeline techniques having complex and reduced instruction set computers computing mechanisms with a clock speed of 500 mega floating point operations (flops, 500 Mega Hertz per cycle) based Pentium-III computer running under windows (MS-DOS partitioned) operating system's environment.

Software

1. Electromyography automatic signal detection, identification, capturing, recording and analyzing procedure (computer real-time on-line software programs developed here)
2. A C/C++ language processor (compiler)
3. A Mat_Lab (Ver. 5.1 and 5.3) with basic modules, processing tool kits, such as, signal and image processing purpose
4. A real-time multi-channel on-line ADC program for digital level storage (developed here).

5. A diagnostic software (for both system and application programming) for EMG Writer's Cramp analysis
6. Various mathematical simulation modeling, analysis techniques and algorithms (PCA, signal decomposition, simple and hierarchical clustering, canonical correlation/multidimensional scaling, coherence, software programmes (utility tools developed here) in C/C++ language processors (compilers), and Mat_Lab (a language of technical computing of IBM mathematica in particular signal and image and neural computing processing).
7. A computer algorithm (software) developed here for removing signal noise (contamination) distortion blocks like horse jumps from the acquired EMG waveforms/signals.
8. Software (programmes) developed for solving Eigen values and Eigen vectors and then for clustering analysis in C/C++ language, numerical algorithms (NAG) routines used.

All these can be seen in the experimental set-up (virtual diagram) shown here (below Fig. 1)

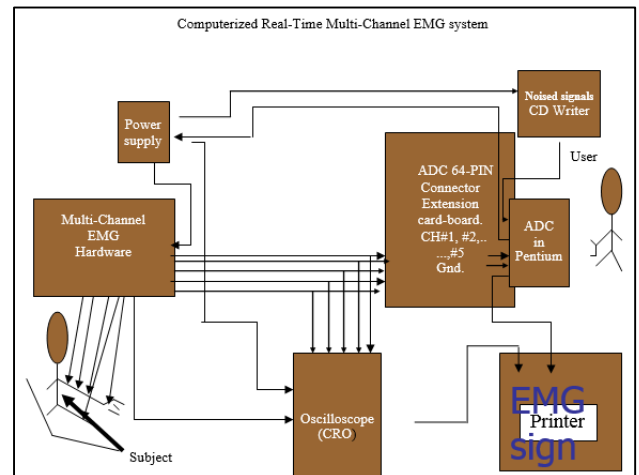

Fig 1: EMG Experimental set-up (virtual)

Conflicts of Interest

All contributing authors declare no conflicts of interest.

Source of Funding

None.

References

1. John V Basmajian, Carlo J De Luca, "Muscles Alive: Their Functions Revealed by Electromyography", 5th edition 1985. Williams and Wilkins Publishing Comp., Baltimore, USA.
2. Jun Kimura and Q. Stokes Dickins. "Electrodiagnosis of Neuromuscular Disorders, Neurol. in Clinical Practice (Principles of Diagnosis & Management)", 1992;II:452-67.
3. Joseph Good Gold, Arthur Eberstein, "Electrodiagnosis of Neuromuscular Diseases", The Williams & Wilkins Company 1977; 2nd Edition.

4. H. Miyano, T. Masuda, and T. Sadoyama, "A note on the time constant in low pass filtering of rectified surface EMG". *J IEEE Trans on BME* 1980;BME-27(5):274-8.
5. Tohru Kiryu, Kohsei Takahashi, and Katsunori Ogawa, "Multivariate Analysis of Muscular Fatigue During Bicycle Ergometer Exercise". *J IEEE Trans Biomed Eng (BM)*, 1997;44(8):665-75.
6. Ronald S. Le Fever, Carlo J.DeLuca., "A Procedure for Decomposing the Myoelectric Signal Into Its Constituent Action Potentials - PART I: Technique, Theory, and Implementation", *J IEEE-Trans Biomed Eng.* Vol. BME-29, No. 3, March, pp: 149-157, 1982.
7. Ronald S. LeFever, Carlo J.DeLuca., "A Procedure for Decomposing the Myoelectric Signal Into Its Constituent Action Potentials - PART II: Execution and Test for Accuracy". *J IEEE-Trans Biomed Eng* 1982;29(3):158-63.
8. Willison, R.G. "Analysis of electrical activity in healthy and dystrophic muscle in man", *Journal of Neurology.Neurosurgery. Psychiatry.* 1964;27:386-94.
9. Lago P J, Jones N.B., "Mathematical Models of Aspects of the Electrical and Mechanical Activity of Human Muscle", D.Phil. thesis, University of Sussex, Susses, England, UK, 1977.

How to cite: VR Raju, Dystonia writer's cramp and botox in WCs – Study with ARTEMG 2. *IP Int J Aesthet Health Rejuvenation* 2020;3(4):101-6.